

LUBRICATE ALL SEALS PRIOR TO ASSEMBLY.  
DO NOT USE SILICONE BASED LUBRICANTS.

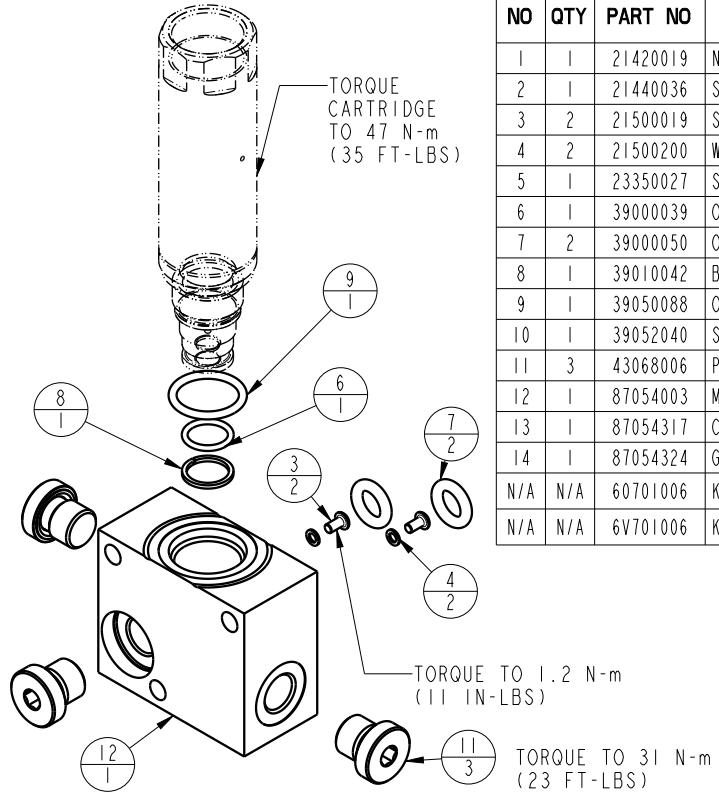

NO	QTY	PART NO	DESCRIPTION	STD SEAL KIT	FKM SEAL KIT
1	1	21420019	NUT, HEX, 3/8-64, SST		
2	1	21440036	SCREW, SET, FP, 3/8-64 x 1 1/8, SST		
3	2	21500019	SCREW, CAP, BTNH, M3 X 6, ALY		
4	2	21500200	WASHER		
5	1	23350027	SPRING, COMPRESSION		
6	1	39000039	O-RING, (-014)	X	
7	2	39000050	O-RING, (-204)	X	
8	1	39010042	BU RING, (-014)	X	X
9	1	39050088	O-RING, (-910)	X	
10	1	39052040	SEAL, LL, (3/8 X 1/8 X 5/32 X 5/8)	X	X
11	3	43068006	PLUG, PORT, HOLLOW HEX, G1/4		
12	1	87054003	MANIFOLD, PRV, METRIC		
13	1	87054317	CAP, PRV		
14	1	87054324	GUIDE, SPRING, UPPER, PRV		
N/A	N/A	60701006	KIT, SEAL, MANIFOLD, PRV, 150-900PSI	NOTED	N/A
N/A	N/A	6V701006	KIT, SEAL, FKM, MANIFOLD, PRV, 150-900PSI	N/A	NOTED

<b>PARTS LIST</b>	
	VEKTEK, INC. 1334 E. SIXTH AVE. P.O. BOX 625 EMPORIA, KS. 66801 U.S.A.
	<b>PARTS LIST, MANIFOLD, PRV, 10-62 BAR</b>
ASSEMBLIES AFFECTED 47054003 47054003F L7051200	SIZE A <b>MPLV4706</b>
	REV B

B	4534	RELEASE	ALS	9/30/21
REV	IN ACCORDANCE WITH ECN	EFFECTIVE DATE	REVISED BY	DATE
DRW BY: DKC	<b>DRAWING STATUS: Released</b> PRODUCTION APPROVED FOR RELEASED STATUS ONLY			
DATE: 6/26/15				